



S-Flex enclosed
variable speed drives

- **Introduction.....30**
 - Applications31
 - Product.....32
 - Functions.....33
- **Specifications34**
 - Electrical34
 - Environmental.....34
 - I/O & Control.....35
- **Selection Tables.....36**
 - Dimensions36
- **Accessories & Options.....38**
 - More Accessories & Options.....39
- **Quality Assurance.....40**
- **Services & Support.....42**

S-Flex enclosed variable speed drives

Introduction



Introduction

Take advantage of the Altivar 212 features by selecting the S-Flex enclosed version. The S-Flex provides an Altivar 212 packaged with the most common options required for commercial fan and pump applications. The **S-Flex** drive is an enclosed frequency converter for **1-100 HP, 0.75-75 kW three-phase asynchronous motors**.

Save Time

Because specifying drives can be time-consuming, the S-Flex drive includes the most common requirements in HVAC specifications for fan and pump applications, such as:

- Simple start-up including preprogrammed parameters
- Quick installation with EZ-M mounting
- Easy wiring conduit knockouts on the enclosure
- Dedicated wiring terminal block
- Stock availability with bypass and main circuit breaker

Save Money

Offering unmatched value in installed cost and functionality, the S-Flex drive allows building owners, consulting engineers, and contractors to focus on the essentials of demanding commercial building applications.

More than dollars and cents, you'll save with:

- Industry-leading reduced harmonic technology — eliminating the need for line reactors and DC chokes
- Energy savings — designed with energy economizing motor algorithms that maximize energy savings by reducing electricity usage
- Internal PID regulator — allowing flow rates to be adjusted for actual needs without additional hardware
- Reduced equipment maintenance cost and downtime
- 24/7 live technical support

Think Green

The S-Flex enclosed drive assists with Leadership in Energy and Environmental Design (LEED®) certification. Green buildings enhance occupant comfort and health, decrease vacancy rates, increase building valuation, and improve the bottom line by reducing operating costs. A building that runs smoothly ensures comfortable tenants, and comfortable tenants mean less vacancy.

Going green with the S-Flex drive offers:

- Building owners the ability to take advantage of state and local government energy incentives
- More marketable buildings to tenants seeking energy-efficient/sustainable facilities
- Retrofitting to existing systems
- The most efficient method of reduced speed and load control



Save Time



Save Money



Think Green

S-Flex enclosed variable speed drives

Introduction



S-Flex enclosed drive, door closed

Applications

Optimization of building management

The S-Flex enclosed drive considerably improves building management by:

- Simplifying circuits by removing flow control valves and dampers,
- Offering flexibility and ease of adjustment for installations, thanks to its compatibility with building management system connectivity
- Reducing noise pollution (noise caused by air flow and motor)

Its various standard versions make it possible to reduce installation costs by integrating EMC filters, categories C1 to C3 depending on the model, which has the following advantages:

- Compact size
- Simplified wiring

The S-Flex enclosed offer helps to reduce equipment costs while optimizing its performance.

Reduced Harmonic Technology

The S-Flex drive revolutionizes harmonic mitigation with its innovative reduced harmonic technology. Significant harmonic reduction is achieved within the diode capacitor and power conversion section of the variable frequency drive, eliminating the need for a line reactor or bus reactor, which results in:

- Higher equipment efficiency
- Reduced equipment cost
- Fewer points of electrical failure
- Smaller enclosure size
- Lighter weight

Harmonics can be present in voltage, current, or both. Any power source that converts AC to DC can generate harmonics. Typical sources include:

- Office equipment
- Computers
- Medical equipment
- Microprocessors
- Uninterruptible power supplies
- Fluorescent lamp ballasts

Harmonic currents do not add additional power to the electrical system, but additional current flows through electrical wires. Effects may include:

- Overheating of electrical distribution system wiring
- Shortened transformer life
- Decreased power factor
- Disturbance of power measuring systems

Altivar 212 with RHT compared to traditional 6-pulse rectifiers

The figure to the left shows a typical waveform of the Altivar 212 drive controller's output current using a 460 V Altivar 212 (15 HP) and Schneider Electric's HarmCalc software per IEEE 519 recommendations for calculating harmonic distortion in <600V applications. The motor control processor and the motor control algorithm are designed to produce a sinusoidal waveform with very little distortion to the motor.

With lower DC bus capacitance, the Altivar 212 drive controller has a reduced capacity to ride through AC power line dips or sags. The Altivar 212 drive controller has an auto-restart feature and a robust catch-on-the-fly algorithm designed to minimize the effect of voltage dips and sags. The catch-on-the fly algorithm has also proven to do an exceptional job of catching a reverse spinning load, bringing the load to a standstill and accelerating in the proper direction. This catch-on-the-fly algorithm is a useful feature for wind-milling fan loads. If voltage ride-through is a major concern in an installation, the Altivar 61, with its industry leading voltage sag ride-through capability may be the preferred solution.

Drive description	THDI (% of fundamental drive current)
6-pulse, no added impedance	163% ⁽¹⁾
6-pulse, 3% AC reactor or DC bus choke	44.6%
6-pulse, 5% AC reactor or DC bus choke	31.8%
ATV212, no added impedance	31.1%
ATV212, 1.5% AC reactor	30.8%

(1) Higher than fundamental current due to mathematical model

Product

The S-Flex range of enclosed variable speed drives extends across a range of motor power ratings:

- 200...240 V three-phase, 1 HP to 40 HP, 0.75 kW to 30 kW, IP 21
- 380...480 V three-phase, 1 HP to 100 HP, 0.75 kW to 75 kW, IP 21
- 380...480 V three-phase, 1 HP to 100 HP, 0.75 kW to 75 kW, UL Type 12/IP 55

The S-Flex range also includes:

- Optional three-phase AC line reactor for line transient protection and even further line harmonic reduction
- Altivar™ 212 drive power converter with reduced harmonic technology and an IGBT inverter with pulse-width modulated output
- Optional LCD text keypad
- Built-in Modbus, BACnet®, Metasys® N2, APOGEE® P1 communication capability, and options for LonWorks®
- Smoke purge override and fan damper control in both Adjustable frequency controller (AFC) and bypass modes of operation
- Adjustable frequency controller — off — bypass selector switch
- Optional drive input disconnect switch provides an input line power disconnect switch between the main power disconnect and the power converter
- Optional line contactor provides an electrically interlocked line contactor between the main power disconnect and the power converter
- Power-on mode red LED indicator
- Bypass mode green LED indicator
- Terminal block for customer's control connections
- Full-voltage bypass contactors
- 100 kAIC UL® 508C rating and full-voltage bypass
- Square D circuit breaker or fused disconnect for power interruption and overcurrent protection
- Hinged door with latches for quick and easy interior access
- Conduit knockouts on bottom of enclosure for quick and easy wiring

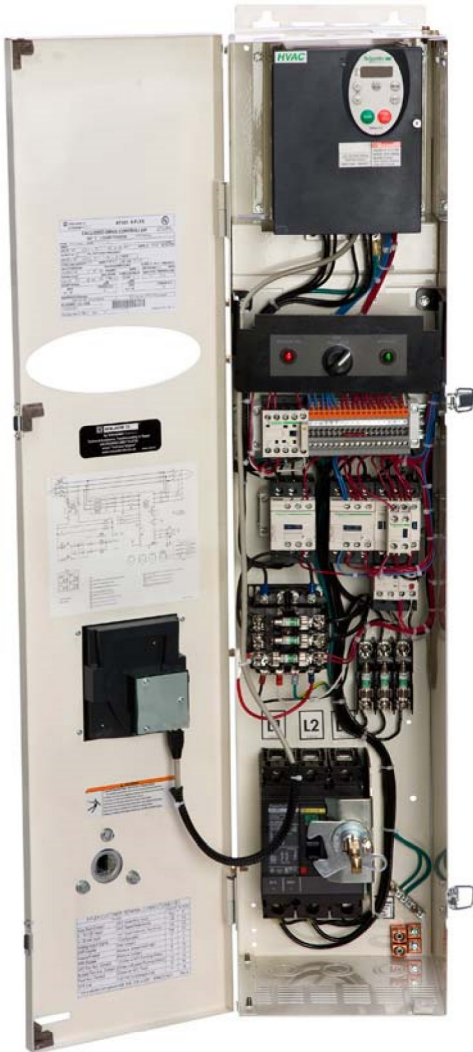

S-Flex enclosed drive, door open

Product (continued)

Features

(1) Keypad display for configuration and monitoring

- Optional LCD keypad

(2) Through-the-door disconnect

- Electrical disconnect circuit breaker handle with electrical lock-out/tag-out

(3) Front access selector and lights

- Adjustable frequency controller — off — bypass selector switch
- Power-on mode red LED indicator
- Bypass mode green LED indicator

(4) EZ-M channel mounting

- Having the interface built into the enclosure makes parallel alignment of multiple drives quick and easy with an EZ-M mounting channel

(5) Hinged NEMA 1-rated enclosure

- Hinged door for quick and easy interior access
- Run status LED

(6) Conduit knockouts

- Conduit knockouts on bottom of enclosure for quick and easy wiring to line and load terminals and control wiring terminations

(7) Short-circuit protection

- Square D circuit breaker offers electrical disconnect and overcurrent protection
- 100,000 A interrupt current (AIC), fully coordinated current rating to UL 508C and NEMA ICS7.1

(8) Bypass contactor

- Full-voltage bypass contactors with electrical interlocks allow for emergency full-speed operation
- Damper Control and Smoke Purge relays for BAS interface

(9) Terminal block

- Easy customer control wiring interface with terminal block connections

(10) Three-phase AC line reactor

- Optional factory mounted and wired to provide increased protection from line transients as well as further reduction in drive-generated line harmonics

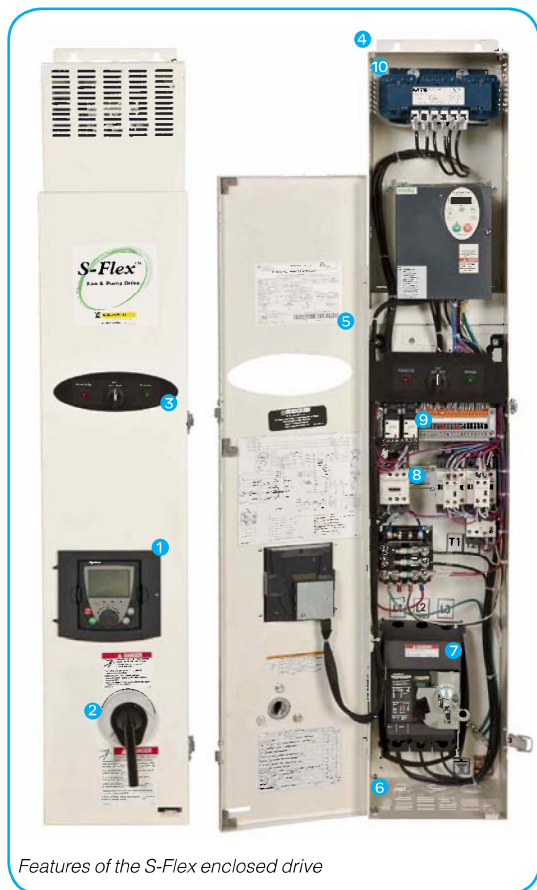

Features of the S-Flex enclosed drive

Functions

The S-Flex™ 212 enclosed drive is a full-featured adjustable speed package solution for variable torque applications. The S-Flex enclosed drive is a bypass package that includes an Altivar™ 212 adjustable speed drive on a wall-mountable back plane with pre-packaged model number options for both power and control functions. The following features are available for the standard bypass package:

- AFC-Off-Bypass selector switch
- Local/Remote configurable on controller
- Power On red LED
- Bypass Run green LED
- Freeze/Firestat interlock
- Form C AFC detected fault contact
- Modbus™ RJ-45 communication port
- Smoke purge and damper control relays
- Circuit breaker disconnect
- Optional line disconnect switch or line contactor
- Optional full text keypad
- Optional non-bypass power circuit

S-Flex enclosed variable speed drives

Specifications Electrical & Environmental

Electrical Specifications

Input	Voltage	V	208 Vac \pm 10%, 230 Vac \pm 10%, 460 Vac \pm 10%
	Frequency	Hz	50...60 \pm 5%
Displacement power factor			Approximately 0.96%
Output voltage		V	Three-phase output, maximum voltage equal to input voltage
Frequency range of the power converter		Hz	0.5...500 (factory setting of 60 Hz maximum)
Configurable switching frequency		kHz	Selectable from 6 to 16 kHz Factory setting: 12 kHz ⁽¹⁾ 1–20 hp; 8 kHz ⁽²⁾ above 25 hp
Speed reference			AI1: 0 V to +10 V, impedance = 30 kOhms AI3: 4 mA to 20 mA, impedance = 250 kOhms 0 mA to 20 mA (reassignable, X – Y range with keypad display), manual speed control via keypad
Inputs and outputs			Three multifunction programmable logic inputs Two analog inputs; VIA (4 mA to 20 mA or 0 V to 10 V), VIB (0 V to 10 V) One analog output; X mA to Y mA or 0 V to 10 V, software selectable Two assignable output relays; one fault relay, one assignable relay, one RJ45 RS485 Modbus port
Current limit			150% of nominal drive full-load amperage (FLA) for 60 s
Electrical isolation			Galvanic isolation between power and control (inputs, outputs and power supplies)
Frequency resolution in analog reference		Hz	0.1 Hz to 100 Hz (10 bits)
Speed regulation			V/f: determined by motor slip, typically 3% SLFV (sensorless flux vector): 1%
Efficiency			Typically greater than 95%
Reference sample time			2 ms
Acceleration and deceleration ramps			0.1 s to 999.9 s (adjustable in 0.1 s increments)
Motor protection			Class 10 and Class 20 overload protection with bypass in addition to controller internal electronic thermal protection
Keypad display			Self-diagnostics with status messages. 7-segment LED display (standard) Full text keypad, 8 languages (optional) Also see Altivar 212 Installation Guide

Environmental Specifications

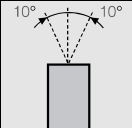
Enclosure type⁽³⁾			UL Type 1
Vibration resistance (Power converter only)	Drive not mounted on DIN rail		According to IEC 60068-2-6: ■ 1.5 mm peak to peak from 3 to 13 Hz ■ 1 g from 13 to 150 Hz
Shock resistance (Power converter only)			15 gn for 11 ms conforming to EN/IEC 60068-2-27
Maximum ambient pollution Definition of insulation			Pollution degree 2 per NEMA ICS-1 and IEC 60664-1
Environmental conditions use			IEC 60721-3-3 classes 3C1 and 3S2
Relative humidity		%	95% with no condensation or dripping water, conforming to IEC 60068-2-3.
Ambient air temperature	Operation	°C	-10 to + 40 operational without de-rating, up to 50 with de-rating. See Installation manual for deratings
	Storage around the device	°C	- 25...+ 70 with vent cover removed and without derating
Maximum operating altitude		m	Up to 3,300 ft (1,000 m) without de-rating, de-rate nominal current by 1% for each additional 330 ft (100m) up to 10,000 ft (3,000 m) Limit to 6,600 ft (2,000 m) if supplied by corner grounded distribution system
Transit test to shock			Conforms to International Safe Transit Association guidelines
Codes and standards			UL/cUL Listed per UL508C as incorporating Class 10 electronic and electromechanical overload protection. Conforms to applicable NEMA ICS, NFPA, IEC, and ISO 9001 standards. Seismic Certification: ■ IBC, NFPA 5000 and ASCE7 ■ ICC ES AC 156 ⁽⁴⁾
Operating position Maximum permanent angle in relation to the normal vertical mounting position			

(1) Above 12 kHz derate the drive per the graphs in the Altivar 212 Installation Guide, S1A53832.

(2) Above 8 kHz derate the drive per the graphs in the Altivar 212 Installation Guide, S1A53832.

(3) Plenum rated; suitable for placement in a compartment handling conditioned air.

(4) Acceptance criteria test protocol with an importance factor of 1.5.

S-Flex enclosed variable speed drives

Specifications I/O & Control

Bypass Power Circuit Y

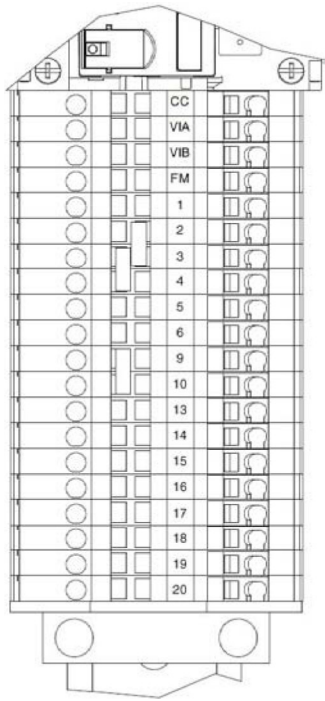

I/O & Control Specifications

	Function	Description	Customer Terminals (Bypass power circuit Y)	
With bypass	0–10 Vdc Input	AFC Speed Reference	VIB	CC
	4–20 mA or 0–10 Vdc Input	AFC Speed Reference ⁽¹⁾	VIA	CC
	Analog Output Signal	Configurable	FM1	CC
	Smoke Purge Relay Disable	Add Jumper	1	2
	Freeze/Firestat	Remove Jumper / Add Interlock	2	3
	Damper End Switch Enable	Remove Jumper	3	4
	Auto Start Contact	AFC Mode Run Input	5	6
	Smoke Purge Relay Disable	Remove Jumper	9	10
	System Run Auxiliary Contact	Closes on Motor Running (AFC or BYP)	13	14
	AFC Trip Auxiliary Contact	Closes on AFC Trip	15	16
	Smoke Purge Relay Coil	120 Vac to Energize Coil	17	18
	Open Damper Signal	Closes when Run Signal Provided	19	20

Non-Bypass Power Circuit W

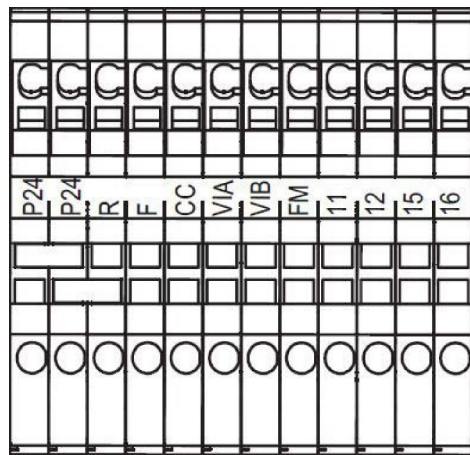

	Functions	Description	Customer terminals (Non-bypass power circuit W)	
Without bypass	Auto Start Contact	AFC Mode Run Input	P24	F
	Freeze/Firestat	Remove Jumper / Add Interlock	P24	R
	0–10 Vdc Input	AFC Speed Reference	VIB	CC
	4–20 mA or 0–10 Vdc Input	AFC Speed Reference ⁽¹⁾	VIA	CC
	Analog Output Signal	Configurable	FM1	CC
	AFC Run Auxiliary Contact	Closes with AFC Running Motor ⁽¹⁾	11	12
	AFC Detected Fault Auxiliary Contact	Closes on AFC Detected Fault	15	16

⁽¹⁾ Factory set for current control. To change the input VIA to voltage control, see Altivar 212 Programming and Operation Guide, S1A53838.

S-Flex enclosed variable speed drives

Selection Tables 208/230 Vac



S-Flex enclosed drive, frame size A

S-Flex drives

Input Voltage 60 Hz	HP ⁽¹⁾	kW	Input current	Output current	Max. transient output current 60 s	Total dissipated power at rated load	S-Flex catalog number ⁽²⁾	Weight		Frame size	Power converter part number ⁽⁵⁾
			A ⁽³⁾	A ⁽¹⁾	A ⁽¹⁾	W ^(1,4)		lbs	kg		
208 Vac	1	0.75	3.3	4.8	5.1	184.2	SFD212CG2•	52	23.587	A	ATV212H075M3X
	2	1.5	6.1	7.8	8.3	228.3	SFD212DG2•	52	23.587	A	ATV212HU15M3X
	3	2.2	8.7	11	11.7	256.0	SFD212EG2•	52	23.587	A	ATV212HU22M3X
	5	4	15.7	17.5	19.3	326.8	SFD212FG2•	52	23.587	A	ATV212HU40M3X
	7.5	5.5	20.8	25.3	36.6	384.7	SFD212GG2•	52	23.587	A	ATV212HU55M3X
	10	7.5	27.9	32.2	35.2	495.0	SFD212HG2•	52	23.587	A	ATV212HU75M3X
	15	11	42.1	48.3	50.4	641.2	SFD212JG2•	111	50.349	B	ATV212HD11M3X
	20	15	56.1	62.1	67.1	846.1	SFD212KG2•	111	50.349	B	ATV212HD15M3X
	25	18.5	67.3	78.2	82.3	939.1	SFD212LG2•	111	50.349	B	ATV212HD18M3X
	30	22	80.4	92	96.8	1017.6	SFD212MG2•	140	63.503	C	ATV212HD22M3X
230 Vac	1	0.75	2.8	4.2	5.1	183.1	SFD212CG3•	52	23.587	A	ATV212H075M3X
	2	1.5	5.3	6.8	8.3	226.1	SFD212DG3•	52	23.587	A	ATV212HU15M3X
	3	2.2	7.6	9.6	11.7	252.1	SFD212EG3•	52	23.587	A	ATV212HU22M3X
	5	4	13.5	15.2	19.3	323.5	SFD212FG3•	52	23.587	A	ATV212HU40M3X
	7.5	5.5	18.1	22	26.6	381.0	SFD212GG3•	52	23.587	A	ATV212HU55M3X
	10	7.5	24.4	28	35.2	489.1	SFD212HG3•	52	23.587	A	ATV212HU75M3X
	15	11	35.7	42	50.8	630.6	SFD212JG3•	111	50.349	B	ATV212HD11M3X
	20	15	47.6	54	67.1	829.5	SFD212KG3•	111	50.349	B	ATV212HD15M3X
	25	18.5	58.0	68	82.3	918.3	SFD212LG3•	111	50.349	B	ATV212HD18M3X
	30	22	69.0	80	96.8	994.1	SFD212MG3•	140	63.503	C	ATV212HD22M3X
	40	30	93.0	104	128.7	1378.4	SFD212NG3•	206	93.440	D	ATV212HD30M3X

- (1) These power, amperage, and wattage ratings apply to:
 -Power converters ATV212H075••• to HD15••• (1–20 hp) operating at a switching frequency of 12 kHz, and at 40 °C (104 °F) ambient temperature.
 -Power converters ATV212HD18••• to HD75••• (25–100 hp @ 460 V) operating at a switching frequency of 8 kHz, and at 40 °C (104 °F) ambient temperature.
 For a switching frequency between 13 kHz and 16 kHz, select the next largest size drive. If the duty cycle does not exceed 60% (36 s for a 60 s cycle) this is not necessary.
- (2) The "•" indicates that the catalog number can end in a "Y" (for an S-flex drive with full voltage bypass) or a "W" (for an S-Flex drive without bypass).
- (3) Select the conductor based on the input line current or the motor FLA, whichever is greater.
- (4) For btu/hr, multiply values by 3.413.
- (5) Drives shown in the table are installed in SFD212 controllers.

Options

Communication set-up options		Miscellaneous options	
A06	BACnet Card	A07	Drive input disconnect
B06	LonWorks Card	B07	Line Contactor
C06	Metasys N2 Card	S07	Seismic certification
D06	Apogee P1 Card	D07	Full text keypad
N06	Modbus	X07	AC line reactor

Dimensions

Frame Size	W x H x D	
	Inches	mm
A	8.714 x 40.375 x 7.895	221.3 x 1025 x 200.5
B	12.215 x 45.142 x 8.725	310.3 x 1146.6 x 221.6
C	12.532 x 62.006 x 10.916	318.3 x 1575 x 277.3
D	15.243 x 64.9 x 11.915	387.5 x 1648.5 x 302.7

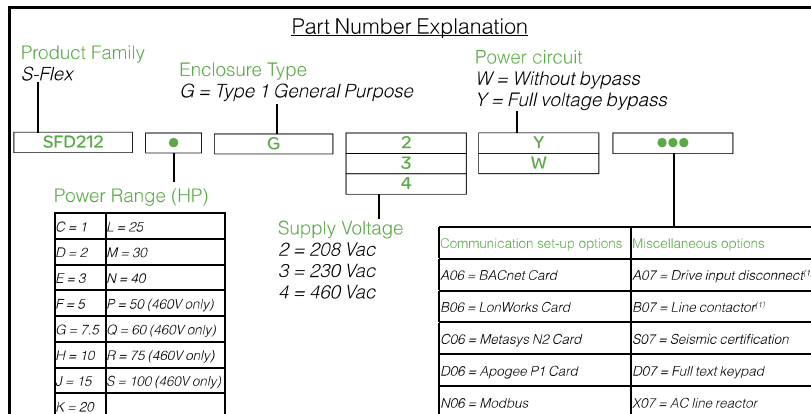

S-Flex enclosed variable speed drives

Selection Tables

460 Vac

S-Flex drives

Input voltage 60 Hz	HP ⁽¹⁾	kW	Input current	Output current	Max. transient output current 60 s	Total dissipated power at rated load	S-Flex catalog number ⁽²⁾	Weight		Frame size	Power converter part number ⁽⁵⁾
			A ⁽³⁾	A ⁽¹⁾	A ⁽¹⁾	W ^(1,4)		lbs	kg		
460 Vac	1	0.75	1.4	2.1	2.4	173.1	SFD212CG4•	52	23.587	A	ATV212H075N4
	2	1.5	2.5	3.4	4	197.6	SFD212DG4•	52	23.587	A	ATV212HU15N4
	3	2.2	4.9	4.8	5.6	224.7	SFD212EG4•	52	23.587	A	ATV212HU22N4
	5	4	6.4	7.6	10	303.6	SFD212FG4•	52	23.587	A	ATV212HU40N4
	7.5	5.5	8.6	11	13.2	352.5	SFD212GG4•	52	23.587	A	ATV212HU55N4
	10	7.5	11.7	14	17.6	418.8	SFD212HG4•	52	23.587	A	ATV212HU75N4
	15	11	16.9	21	24.8	572.9	SFD212JG4•	52	23.587	A	ATV212HD11N4
	20	15	22.6	27	33.6	765.8	SFD212KG4•	111	50.349	B	ATV212HD15N4
	25	18.5	27.8	34	40.7	766.5	SFD212LG4•	111	50.349	B	ATV212HD18N4
	30	22	33.1	40	47.9	806.0	SFD212MG4•	140	63.503	C	ATV212HD22N4
	40	30	44.7	52	64.4	1041.5	SFD212NG4•	140	63.503	C	ATV212HD30N4
	50	37	54.4	65	86.9	1241.6	SFD212PG4•	140	63.503	C	ATV212HD37N4
	60	45	65.9	77	103.4	1622.1	SFD212QG4•	140	63.503	C	ATV212HD45N4
	75	55	89	96	127.6	2007.5	SFD212RG4•	206	93.440	D	ATV212HD55N4
	100	75	111.3	124	176	2866.8	SFD212SG4•	206	93.440	D	ATV212HD75N4

- (1) These power, amperage, and wattage ratings apply to:
 -Power converters ATV212H075●●● to HD15●●● (1-20 hp) operating at a switching frequency of 12 kHz, and at 40 °C (104 °F) ambient temperature.
 -Power converters ATV212HD18●●● to HD75●●● (25-100 hp @ 460 V) operating at a switching frequency of 8 kHz, and at 40 °C (104 °F) ambient temperature.
 For a switching frequency between 13 kHz and 16 kHz, select the next largest size drive. If the duty cycle does not exceed 60% (36 s for a 60 s cycle) this is not necessary.
- (2) The "•" indicates that the catalog number can end in a "Y" (for an S-flex drive with full voltage bypass) or a "W" (for an S-Flex drive without bypass).
- (3) Select the conductor based on the input line current or the motor FLA, whichever is greater.
- (4) For btu/hr, multiply values by 3.413.
- (5) Drives shown in the table are installed in SFD212 controllers.



S-Flex enclosed drive, frame size A

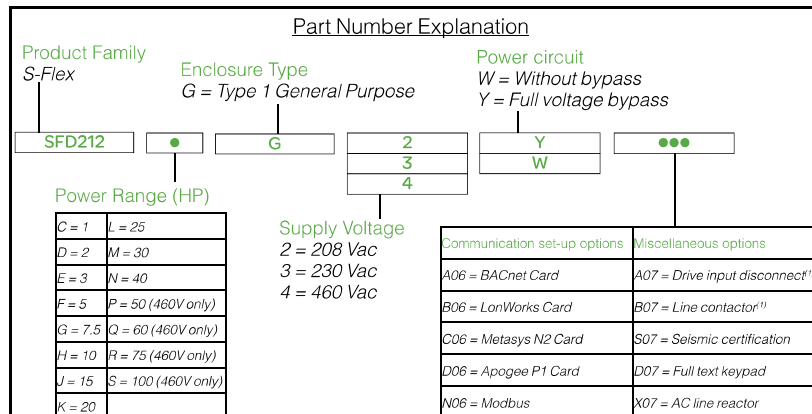

Options

Communication set-up options		Miscellaneous options	
A06	BACnet Card	A07	Drive input disconnect
B06	LonWorks Card	B07	Line Contactor
C06	Metasys N2 Card	S07	Seismic certification
D06	Apogee P1 Card	D07	Full text keypad
N06	Modbus	X07	AC line reactor

Dimensions

Frame Size	W x H x D	
	Inches	mm
A	8.714 x 40.375 x 7.895	221.3 x 1025 x 200.5
B	12.215 x 45.142 x 8.725	310.3 x 1146.6 x 221.6
C	12.532 x 62.006 x 10.916	318.3 x 1575 x 277.3
D	15.243 x 64.9 x 11.915	387.5 x 1648.5 x 302.7

S-Flex enclosed variable speed drives

Accessories & Options

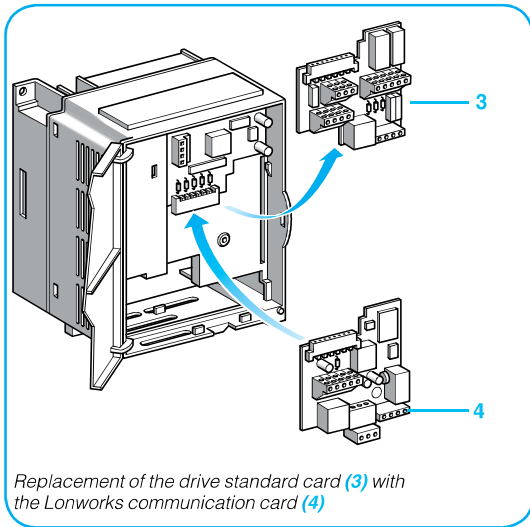

Replacement of the drive standard card (3) with the Lonworks communication card (4)

Optional LonWorks communication card

The Altivar 212 drive can also be connected to the LonWorks network by using the communication card (4) available as an option. It is connected by replacing the standard card (3) on the drive.

The connections are identical to those on the standard card:

- An RJ45 communication port for the Modbus serial link: this network port is mainly assigned to the remote graphic display keypad (Drive Navigator).

It is also used to connect:

- The Multi-Loader configuration tool
- The Bluetooth® serial link
- A Magelis industrial HMI terminal
- A screw terminal block for the Modbus serial link and the LonWorks network (optimized solution for daisy chain connection). This screw terminal block is assigned to control and signalling by a PLC or by another type of controller.

The Altivar 212 drive can be controlled using the LonWorks 6010 (Variable Speed Motor Drive) and LonWorks 0000 (Node Object) profiles.

LonWorks Communication

All the drive functions can be accessed via the network:

- Control
- Monitoring
- Adjustment
- Configuration

The speed control and reference may come from different sources:

- I/O terminals
- Communication network
- Drive Navigator

The advanced functions of the Altivar 212 enable switching of these drive control sources to be managed in accordance with the application requirements.

Communication is monitored according to criteria specific to each protocol.

However, regardless of the protocol, it is possible to configure how the drive responds to a communication fault:

- Freewheel stop, stop on ramp or braked stop
- Maintain last command received



LonWorks communication card VW3 A21 212

Description	Part number	Weight	
		lbs	kg
LONWORKS communication card	VW3A21212	0.4	0.2



iPad programming

The iPad application can perform the following programming actions:

- Create parameter files
- Validate drive configurations
- Upload, download or clone drive settings
- Retain digital file copies of drive settings
- Links to all product information embedded in app